



Committee: LICENSING REGULATORY COMMITTEE

Date: THURSDAY, 16 JULY 2015

Venue: LANCASTER TOWN HALL

Time: 1.00 P.M.

A G E N D A

1. **Apologies for Absence**

2. **Minutes**

Minutes of the meeting held on 4 June 2015 (previously circulated).

3. **Items of Urgent Business authorised by the Chairman**

4. **Declarations of Interest**

To receive declarations by Members of interests in respect of items on this Agenda.

Members are reminded that, in accordance with the Localism Act 2011, they are required to declare any disclosable pecuniary interests which have not already been declared in the Council's Register of Interests. (It is a criminal offence not to declare a disclosable pecuniary interest either in the Register or at the meeting.)

Whilst not a legal requirement, in accordance with Council Procedure Rule 10 and in the interests of clarity and transparency, Members should declare any disclosable pecuniary interests which they have already declared in the Register, at this point in the meeting.

In accordance with Part B, Section 2 of the Code of Conduct, Members are required to declare the existence and nature of any other interests as defined in paragraphs 8(1) or 9(2) of the Code of Conduct.

Matters for Decision

Exclusion of the Press and Public

5. **Confidential Items**

The following report is not for publication because it contains confidential information and will be considered whilst the public are excluded from the meeting. The applicant has been invited to attend and/or be represented at the meeting, but will be asked to leave whilst the Committee makes the decisions, as exempt legal advice may be given.

Members are advised that, in accordance with Section 100A(2) of the Local Government Act 1972, the press and public should be excluded for the following item of business on

the ground that it could include the possible disclosure of confidential information.

6. **Application for a Private Hire and Hackney Carriage Dual Driver's Licence - Darren David Brennand** (Pages 1 - 12)

Report of Licensing Manager

7. **Exempt Items**

The Committee is recommended to pass the following recommendations in relation to the following items:

“That, in accordance with Section 100A(4) of the Local Government Act 1972, the press and public be excluded from the meeting for the following items of business, on the grounds that it could involve the possible disclosure of exempt information, as defined in paragraph 1 of Schedule 12A of that Act.”

Members are reminded that, whilst the following items have been marked as exempt, it is for Committee itself to decide whether or not to consider each of them in private or in public. In making the decision, Members should consider the relevant paragraph of Schedule 12A of the Local Government Act 1972, and also whether the public interest in maintaining the exemption outweighs the public interest in disclosing the information. In considering their discretion Members should also be mindful of the advice of Council Officers.

8. **Existing Hackney Carriage and Private Hire Driver's Licence - Collette Barker** (Pages 13 - 20)

Report of Licensing Manager

9. **Existing Private Hire Driver's Licence - Martin Lionel Payne** (Pages 21 - 37)

Report of Licensing Manager

10. **Existing Hackney Carriage Licence - Maria Wearing** (Pages 38 - 39)

Report of Licensing Manager

11. **Existing Dual Driver's Licence - Martin Andrew Woodcock** (Pages 40 - 44)

Report of Licensing Manager

Public Items

The press and public will be readmitted to the meeting at this point.

12. **Highways Act 1980 - Street Cafe Licence - Juicafe, Market Street, Lancaster - Request for Variation of Standard Conditions in relation to Permitted Times** (Pages 45 - 54)

Report of Licensing Manager

13. **Deregulation Act 2015 - Duration of Private Hire Operator's Licences and Hackney Carriage and Private Hire Driver's Licences and Proposed Fees for Private Hire Operators Licences October 2015 - April 2016** (Pages 55 - 58)

Report of Licensing Manager

14. **Review of Recent Court Cases** (Pages 59 - 60)

Report of Licensing Manager

ADMINISTRATIVE ARRANGEMENTS

(i) Membership

Councillors Margaret Pattison (Chairman), Terrie Metcalfe (Vice-Chairman), Charlie Edwards, Andrew Gardiner, Nigel Goodrich, Tim Hamilton-Cox, Colin Hartley, Rebecca Novell and Robert Redfern

(ii) Substitute Membership

Councillors Claire Cozler, Sheila Denwood, Roger Mace and John Wild

(iii) Queries regarding this Agenda

Please contact Jane Glenton, Democratic Services - telephone (01524) 582068, or email jglenton@lancaster.gov.uk.

(iv) Changes to Membership, substitutions or apologies

Please contact Democratic Support, telephone (01524) 582170, or email democraticsupport@lancaster.gov.uk.

MARK CULLINAN,
CHIEF EXECUTIVE,
TOWN HALL,
DALTON SQUARE,
LANCASTER, LA1 1PJ

Published on Wednesday, 8 July 2015.

Document is Restricted

Document is Restricted

Document is Restricted

Document is Restricted

By virtue of paragraph(s) 1 of Part 1 of Schedule 12A
of the Local Government Act 1972.

Document is Restricted

By virtue of paragraph(s) 1 of Part 1 of Schedule 12A
of the Local Government Act 1972.

Document is Restricted

By virtue of paragraph(s) 1 of Part 1 of Schedule 12A
of the Local Government Act 1972.

Document is Restricted

By virtue of paragraph(s) 1 of Part 1 of Schedule 12A
of the Local Government Act 1972.

Document is Restricted

By virtue of paragraph(s) 1 of Part 1 of Schedule 12A
of the Local Government Act 1972.

Document is Restricted

By virtue of paragraph(s) 1 of Part 1 of Schedule 12A
of the Local Government Act 1972.

Document is Restricted

By virtue of paragraph(s) 1 of Part 1 of Schedule 12A
of the Local Government Act 1972.

Document is Restricted

By virtue of paragraph(s) 1 of Part 1 of Schedule 12A
of the Local Government Act 1972.

Document is Restricted

By virtue of paragraph(s) 1 of Part 1 of Schedule 12A
of the Local Government Act 1972.

Document is Restricted

By virtue of paragraph(s) 1 of Part 1 of Schedule 12A
of the Local Government Act 1972.

Document is Restricted

By virtue of paragraph(s) 1 of Part 1 of Schedule 12A
of the Local Government Act 1972.

Document is Restricted

By virtue of paragraph(s) 1 of Part 1 of Schedule 12A
of the Local Government Act 1972.

Document is Restricted

By virtue of paragraph(s) 1 of Part 1 of Schedule 12A
of the Local Government Act 1972.

Document is Restricted

LICENSING REGULATORY COMMITTEE

**Highways Act 1980
Street Café Licence – Juicafe, Market Street, Lancaster –
Request for Variation of Standard Conditions in relation to
Permitted Times
18th July 2015**

Report of Licensing Manager

PURPOSE OF REPORT

An application for a Street Cafe Licence licence has been received from Mr Oliver Wilson-Fish. Along with his application the applicant has requested a variation of the standard licence condition which allows the street cafe to operate between the hours of 10am and 8pm, to allow him to operate from 7am until 10pm

The report is public

RECOMMENDATIONS

The Committee is requested to determine in the light of the representations made, whether to allow the applicant’s request for a variation of the standard licence condition in relation to the permitted times of operation for the street cafe licence to allow him to operate from 7am to 10pm instead of the standard condition 10am to 8pm

1.0 Introduction

1.1 The Council grants permissions for Street Cafe Licences. Under Section 115E of the Highways Act 1980. Under section 115F of the same Act, a District Council may attach to the grant of a licence under this section such conditions as they may think fit

1.2 For the purpose of the above, the Council has established conditions attached to the grant of Street Cafe Licence.

1.3 In relation to this application condition 4 states:-

The use of the Licensed Area shall cease before 20.00 hours each day and shall not commence prior to 10.00 hours.

1.4 The purpose of this condition is to keep the areas clear of obstruction to allow vehicular access for service vehicles and to allow street cleansing before the commencement of operation of the cafe where necessary.

- 1.5 Mr Wilson-Fish has now submitted a request to operate his Street Cafe area from 7am until 10pm. He has stated on his application form that the only place he has to store his street cafe furniture is within his premise. His premise opens at 7am and he claims that without this variation he would not be able to operate a street cafe as he would not have anywhere to store his furniture. The street cafe would be located outside of his premises on Market Street, Lancaster. A copy of the application is attached at appendix 1 to this report, along with a plan of the area.
- 1.6 As part of the application process County Highways officers and Council Planning officers as well as other businesses in the area of the frontage have been consulted.
- 1.7 The closing date for representations was the 17th June and no representations were received.
- 1.8 Mr Wilson-Fish has been invited to attend the meeting to make representations in support of his request.

2.0 Conclusion

- 2.1 Members are asked to consider whether they are satisfied to allow the applicant's request for variation of the standard condition and to allow the Street Cafe at Juicafe, Market Street, Lancaster to operate from 7am until 10pm instead of the standard 10am until 8pm.

CONCLUSION OF IMPACT ASSESSMENT (including Diversity, Human Rights, Community Safety, Sustainability and Rural Proofing)	
None.	
FINANCIAL IMPLICATIONS	
Financial Services have not been consulted as there are no financial implications.	
LEGAL IMPLICATIONS	
There is no right of appeal against imposition of a condition attached to a Street Café licence.	
BACKGROUND PAPERS	Contact Officer: Wendy Peck Telephone: 01524 582317 E-mail: wpeck@lancaster.gov.uk Ref: WP/DWE
None	

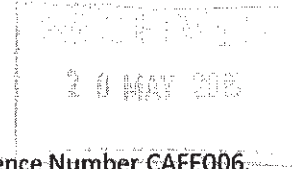

The purpose of this new application is to replace the existing Street Café Licence Number CAFE006.

We are asking for a variation to the licence terms to read:

10.0 The use of the Licenced Area shall cease before 22.00 hours each day and shall not commence prior to 07.00 hours.

In support of the changes to the term the business hosts various local groups which run late into the evening.

As with many other A3 businesses in Lancaster we do not have any miscellaneous storage areas. This means that whilst the business is open, the street furniture needs to be outside. Whilst the business opens at 08.00 hours Mon-Sat and 10.00 hours on Sundays, commencing the licence at 07.00 hours gives the staff the chance to set up fully before each day's trading.

If you have any questions regarding this application I can be contacted best by email on oli@juicafe.co.uk or mobile number 07780462467.

Oliver Wilson-Fish

General Manager

LANCASHIRE COUNTY COUNCIL

FOR OFFICE USE

Application No...

Date...

Fee Paid...

Receipt No...

Application for a Licence to use the Highway for a Street Café
Highways Act 1980 Section 115C-E

20 MAY 2015
268-90

Please read the notes and answer all the following questions

Question 1

Your Name and Address *OLIVER WILSON-ASH*
JULIAH
53, MARKET STREET
LANCASTER
Postcode *LA1 1JG*
Tel. No. *01524880002*

Question 2

Name and address of any person acting for you
Not Applicable

Question 3

Describe the proposed location for the street café and address if different from the address in Q1 above.
As above.

Question 4

Please state the main proposed materials (for example: furniture, umbrellas, boundary markers, colour, type, styles) and show them on your detailed layout plan.
Tables, chairs, barriers, barrier posts.

Question 5

Do you intend to alter any of the building and/or building frontage to accommodate the proposal? If YES, please show details of the alterations on your plan.

YES/NO

Question 6

Are there any lighting columns, litter bins, road signs, public seating, trees, etc. on the site within the boundary of the area proposed for the street café? If YES, please show them on your plan.

YES/NO

Question 7

Is proper sanitary accommodation available within the building to be used to service the Street café?

YES/NO

Question 8

Is it intended to seek a licence to serve alcohol within the street café area?
If YES, please answer Q9 below.

YES NO

Question 9

What range of drinks (alcoholic and non-alcoholic) is it intended will be served within the street café area?

Give details below. *Teas, Coffees, Hot Chocolates, smoothies, juices, bottled carbonated & still soft drinks.*

The applicant should be aware that the granting of a licence does not permit the sale of alcohol within the outdoor café area. Separate licensing arrangements apply for the sale of alcohol and the applicant should check the conditions on the Premises Licence or consult the Licensing Authority.

Question 10

Please read and sign the following statement.

I wish to apply for a licence to use the highway fronting the above named property for the purpose of a street café as described in this application and the accompanying plans and enclose the required fee.

Signed. *[Signature]*

Date. *11/3/15*



6. Management arrangements for street cafe, 53, Market Street.

i/ Barriers and seating will be put out each morning prior to opening.

ii/ Staff will regularly check for tables to be cleared and cleaned throughout the day.

iii/ Barriers and seating will be taken inside at the close of trading each day.

iv/ The area encompassing the street cafe will be swept as needed throughout the day and at close of trading.

27/04/2011

KU CATALINA ARMCHAIR | Stacking Ou...

Company activity *
Estimated pieces *
Estimated timeframe *

Details about your current project: *

I'm interested in the KU CATALINA ARMCHAIR for...

Alternatively you can phone us on 0845 833 8125.

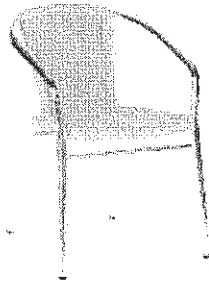

Stackable armchair, seat and back in weave,
available in the following colours:

Beige, Blue, Green, **Black**, Burgundy and Brown.

Frame in aluminium, suitable for outdoor use.

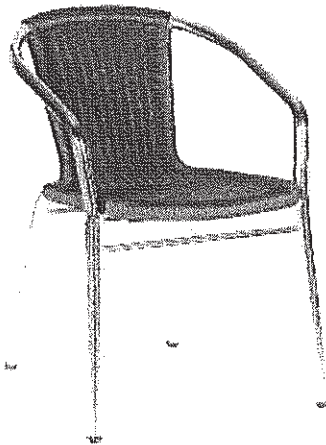

You may also be interested in some of the most respected and valued associations in the hospitality and leisure furniture search industries

The table bases incorporate FLAT echnology. It is a basic pnumatic system which ensures the tables are not wobbly regardless of the surface they are on. Much more important before the improvement works were done. The tables still remain steady on the new improved surface resulting in a reduced chance in customers spilling their purchases. For more info go to:

<http://www.buymodernhospitalityfurniture.com/flat-tech-table-bases>

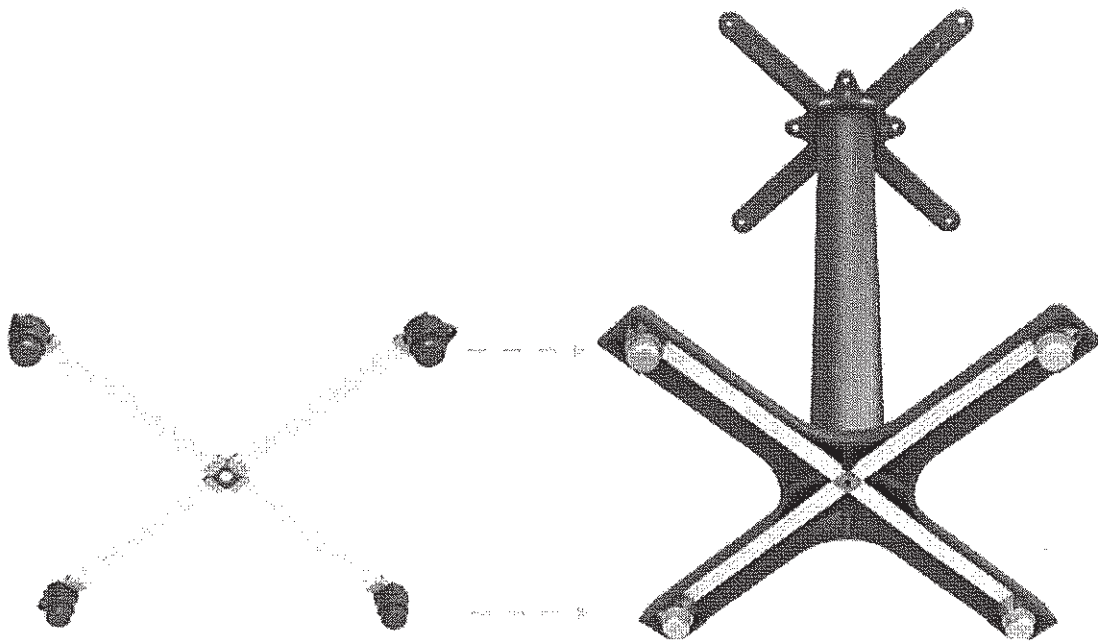

LICENSING REGULATORY COMMITTEE**Deregulation Act 2015 – Duration of Private Hire Operator’s
Licences and Hackney Carriage and Private Hire Driver’s
Licences and Proposed Fees for Private Hire Operators
Licences October 2015 – April 2016
16th July 2015****Report of Licensing Manager****PURPOSE OF REPORT**

To inform members of the amendments to the Local Government (Miscellaneous Provisions) Act 1976 implemented by the Deregulation Act 2015 in relation to the duration of Private Hire Operator’s Licences and Hackney Carriage and Private Hire Driver’s Licences. To ask members to approve the proposed procedure for dealing with the change in legislation in relation to the 5 year operator’s licence.

This report is public.

RECOMMENDATIONS

1. That the Committee approve a consultation with current operators in relation to the introduction of a five year Private Hire Operator’s licence as required by the Deregulation Act 2015.
2. That the Committee approve the issuing of a 6 month operator’s licence for renewals and new applications between the 1st October 2015 and 31st March 2016 so that a full consultation can take place and to allow time to set an appropriate fee for a five year licence.
3. That the committee approve the introduction of a three year driver’s licence for all new applicants in line with the requirements of the Deregulation Act 2015 and the current procedures for existing hackney carriage and private hire drivers.
4. That the committee allow applicants over the age of 65 to continue to renew their driver’s licence on an annual basis in line with the medical check requirement.

1.0 Report

- 1.1 The provisions of the Deregulation Act 2015 that relate to Taxi and Private Hire Licensing come into force on the 1st October 2015.
- 1.2 The Deregulation Act amends the Local Government (Miscellaneous Provisions) Act 1976 LG(MP)A1976 as follows:-

Hackney Carriage and Private Hire Driver's Licences

- 1.3 In relation to hackney carriage and private hire driver's licences the provision in s53 of the Act at the moment requires the Council to grant a licence for a period of 3 years or for 'such lesser period as the district council may specify in such licence.' This provision has been amended to require the Council to grant a licence for 3 years or 'for such lesser period, specified in the licence, as the district council think appropriate in the circumstances of the case'
- 1.4 Members may be aware that in March 2012 this committee approved the introduction of a 3 year driver's licence for all renewal applications except for drivers over the age of 65. The provision for new applicants remained the same and the licence is currently only granted for a year.
- 1.5 Officers are now requesting that in light of the amendment to the legislation members approve with effect from the 1st October 2015 the issue of a 3 year driver's licence for all new applicants in line with the current procedure for renewals. However officers would recommend that the procedure in relation to the issuing of an annual licence to drivers over the age of 65 remains as it is now. This will keep it in line with the requirement to undergo annual medical checks and will not force a driver who may be considering retirement in the near future to pay out for a 3 year licence which will not be used. Officers think that this would be appropriate in the circumstances of the case and would ensure compliance with the amended legislation.
- 1.6 The fee for the 3 year driver's licence for the financial year 2015/16 has already been approved by this committee in February of this year and there will be no requirement for an amendment to that fee as a result of the changes to the legislation.

Private Hire Operator's Licence

- 1.7 The Deregulation Act 2015 amends section 55 of the LG(MP)A1976 which relates to the duration of private hire operator's licences by substituting subsection 2 which currently provides:-

'Every licence granted under this section shall remain in force for such period, not being longer than five years, as a district council may specify in the licence'

With:-

'Every licence granted under this section shall remain in force for five years or for such lesser period, specified in the licence, as the district council think appropriate in the circumstances of the case'
- 1.8 Officers recommend that in light of the above amendment a consultation should now take place with private hire operators to inform them of this change in legislation and to seek their views.
- 1.9 Currently private hire operator's licences are issued annually and the fee is set accordingly. If a five year licence were to be introduced the fee would have to be adjusted to reflect the Council's recoverable costs over the five year period.
- 1.10 Section 70 of the LG(MP)A1976 allows the council to set fees for the grant of vehicle and operator's licences which should be sufficient in aggregate to cover in whole or

in part reasonable costs of inspections of vehicles and any reasonable administrative or other costs associated with the control and supervision of hackney carriage and private hire vehicles.

- 1.11 Any fee charged would have to be sufficient to cover all of the above costs for the full five years of the licence. Officers are concerned that this could cause some smaller operators financial hardship and they may prefer to continue being licensed for one year only. Some operators may not be intending to keep a licence for five years, and again may prefer to be licensed for a shorter period.
- 1.12 Officers will shortly be carrying out a full review of fees for all licences issued utilising information collated through a time recording system currently being used in the licensing department. It is felt that it would be appropriate to consider any proposed fees for a five year operator's licence at the same time. A report will be submitted to this committee in February outlining all proposed fee changes.
- 1.13 In the meantime officers feel it would be appropriate to issue any operator's licences between the 1st October 2015 and 31st March 2016 for a 6 month period. This will mean that all operators' licences will be due for renewal in the same financial year 2016 and will ensure that, if a five year licence is introduced, all operators will benefit from being charged in accordance with the latest fees table. This will also allow officers adequate time to ensure that a full and accurate review of the fees can be carried out and will ensure that the fee charged reflects, as accurately as possible, all allowable charges.

2.0 Conclusion

- 2.1 Members are requested to approve the introduction of a three year hackney carriage, private hire and dual driver's licence for all new applicants.
- 2.2 Members are requested to approve the start of a consultation with private hire operators in relation to the issuing of a five year licence.
- 2.3 Members are asked to approve the introduction of a 6 month operator's licence for all operator licences issued between 1st October 2015 and 31st March 2016.

CONCLUSION OF IMPACT ASSESSMENT

(including Diversity, Human Rights, Community Safety, Sustainability and Rural Proofing)

The proposed change does not have the potential to cause negative impact or discriminate against different groups in the community based on age, disability, gender, race/ethnicity, religion or religious belief (faith), sexual orientation, or rural isolation.

FINANCIAL IMPLICATIONS

As a full review of all licence fees is to be conducted as part of the budget process it is felt that it would be unreasonable to set a figure for a new 5 year licence now until the review is completed. The issuing of a 6 month licence from October to March will result in a shortfall of around £1,400 and that will need to be built into the 2015/16 Revised Budget.

Likewise, introducing a 3 year driver's licence for all but the over 65's will have an impact on year on year budgets and will need to be assessed along with the fee review and again built

into the Revised and future year's budgets as part of the 2016/17 budget process.

LEGAL IMPLICATIONS

The legal implications are included in the report.

BACKGROUND PAPERS

None.

Contact Officer: Wendy Peck

Telephone: 01524 582317

E-mail: wpeck@lancaster.gov.uk

Ref: WP

LICENSING REGULATORY COMMITTEE

**Review of Recent Court Cases
16th July 2015**

Report of Licensing Manager

PURPOSE OF REPORT

To inform members of the outcomes of recent court cases in relation to hackney carriage and private hire drivers.

The report is public

RECOMMENDATIONS

The Committee is requested to note the report.

1.0 Introduction

1.1 Members have requested to be kept informed of licensing court cases, and a quarterly report is provided.

1.2 22nd June 2015

David Leslie Scott of Morecambe pleaded guilty to plying for hire in a vehicle that was not licensed as a hackney carriage vehicle. He was fined £210 and ordered to pay £200 costs and a £21 victim surcharge

2.0 Conclusion

2.1 Members are asked to note the report.

CONCLUSION OF IMPACT ASSESSMENT

(including Diversity, Human Rights, Community Safety, Sustainability and Rural Proofing)

Enforcement of licensing matters helps to assure the public that the Council does consider the issue of the safety of the public.

FINANCIAL IMPLICATIONS

This prosecution was conducted by one of the Council's internal solicitors. The award of costs against the defendant contributes to the cost of the solicitor's time, which is otherwise met from within existing staff budgets.

LEGAL IMPLICATIONS

The Council is responsible for ensuring that the legislation in relation to hackney carriage and private hire licensing is enforced.

BACKGROUND PAPERS

None

Contact Officer: Wendy Peck

Telephone: 01524 582317

E-mail: wpeck@lancaster.gov.uk

Ref: WP